

Basınç Pressure	Kuvvet Force	Tonaj Tonnage
Bar	kN	Kg/Force
50	7	713
100	15	1.529
150	23	2.345
200	31	3.161
250	38	3.874
300	46	4.690
350	54	5.506
400	62	6.322
450	69	7.036
500	77	7.851
550	85	8.667
600	93	9.483
650	100	10.197
700	108	11.012
750	116	11.828
800	124	12644
850	131	13.358
900	139	14.174
950	147	14.989
1.000	155	15.805
1.050	167	17.029
1.100	170	17.335
1.150	178	18.150
1.200	186	18.966
1.250	193	19.680
1.300	201	20.496
1.350	209	21.312
1.400	217	22.127
1.450	224	22.841
1.500	232	23.657

1kN = 101,971 kgf

F = P x A

Etki Alanı = 15,5 cm²

Kuvvet= Basınç x Etki Alanı

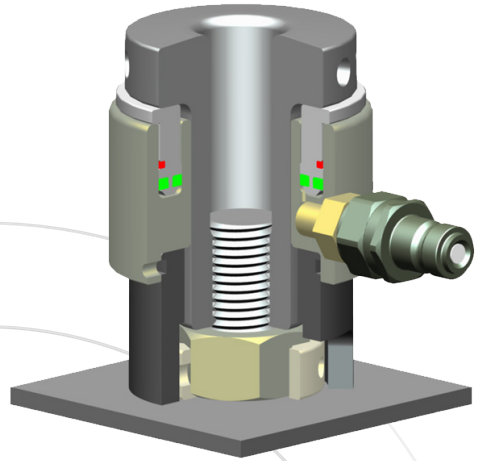
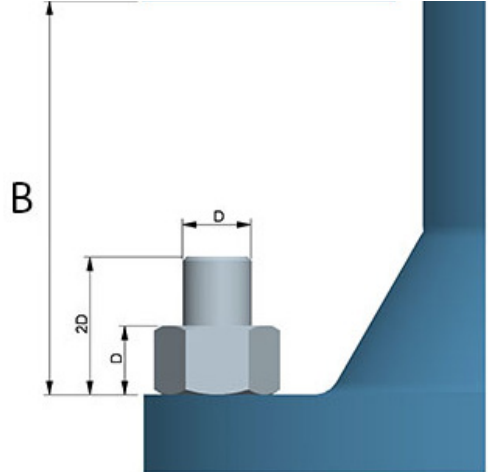
**Surkon Makina Sanayi ve Ticaret LTD. ŞTİ.**

İvedik Organize Sanayi Bölgesi - Özpetek Sanayi Sitesi
1390 Sokak No: 12 - TR-06378 - Yenimahalle / ANKARA
Tel: +90 (312) 386 14 64 / Faks: +90 (312) 386 14 88
info@surkon.com / www.surkon.com



ISO 9001 : 2008
Quality Management System
TS EN ISO /IEC 17021
AB - 0049 - YS
Certificate No: 57812